

TYPICAL TRENCH - GRAVEL ROADWAYS AND EASEMENTS

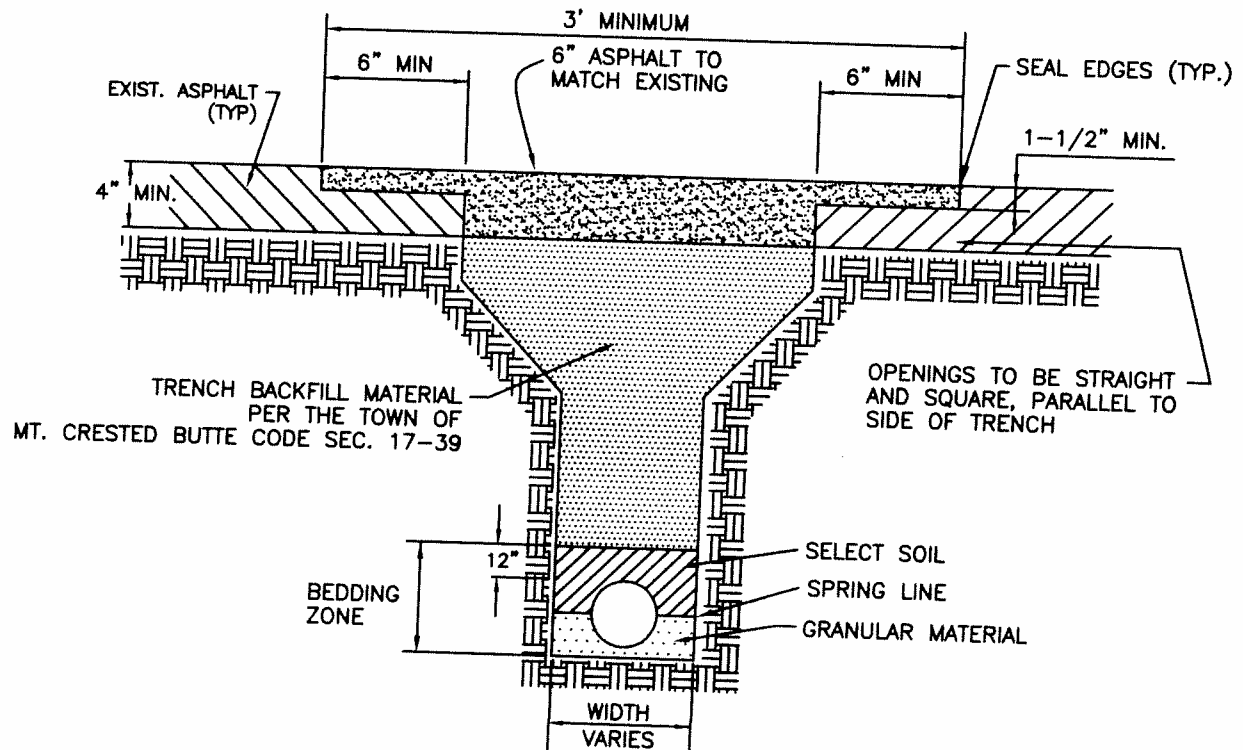

TYPICAL TRENCH AND PAVEMENT REPLACEMENT

GENERAL NOTES

1. EXISTING PAVEMENT SHALL BE CUT WITH PAVEMENT SAW.
2. BEDDING MATERIAL SHALL EXTEND A MINIMUM OF 12-INCHES ABOVE OF PIPE.
3. GRANULAR MATERIAL SHALL BE A MINIMUM OF 4-INCHES BELOW PIPE INVERT.
4. PRIOR TO INSTALLATION OF PATCH, ALL EDGES OF EXISTING ASPHALT SHALL HAVE A TACK COAT APPLIED.
5. ALL SEAMS BETWEEN NEW AND EXISTING PAVEMENT SHALL BE SEALED WITH AN ASPHALT TACK COAT.
6. PAVEMENT SECTION SHALL MATCH EXISTING. NOT LESS THAN 4" OF FULL DEEP ASPHALT SHALL BE USED TO FILL A STREET CUT REGARDLESS OF THE EXISTING CROSS SECTION.
7. REFER TO THE TOWN OF MT. CRESTED BUTTE CODE SECTION 17-39.



TYPICAL TRENCH AND SURFACE REPLACEMENT

APPROVED _____	FLG	DATE APRIL 2008	DWG PAV-SEW	DETAIL S-1
----------------	-----	-----------------	-------------	------------

C:\glick\CAD\win\Stds & Specs\Specs swr\S1-pav-sew.dwg, 5/18/2009 4:03:20 PM

C:\glick\CAD\win\stds & Specs\Specs swr\S2-cut-off.dwg, 5/18/2009 4:06:00 PM

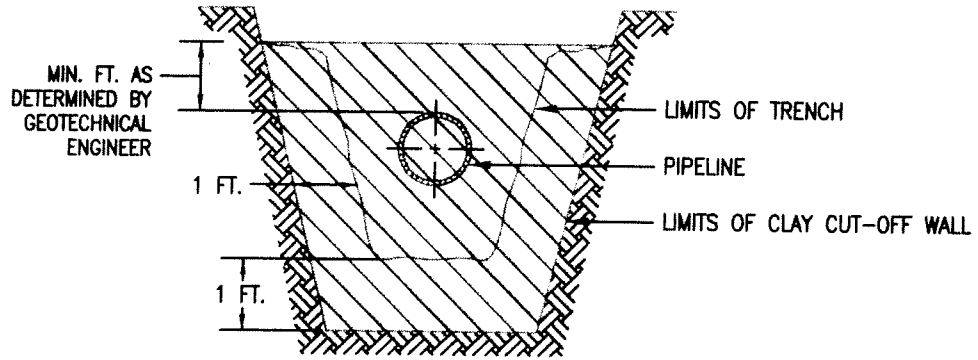
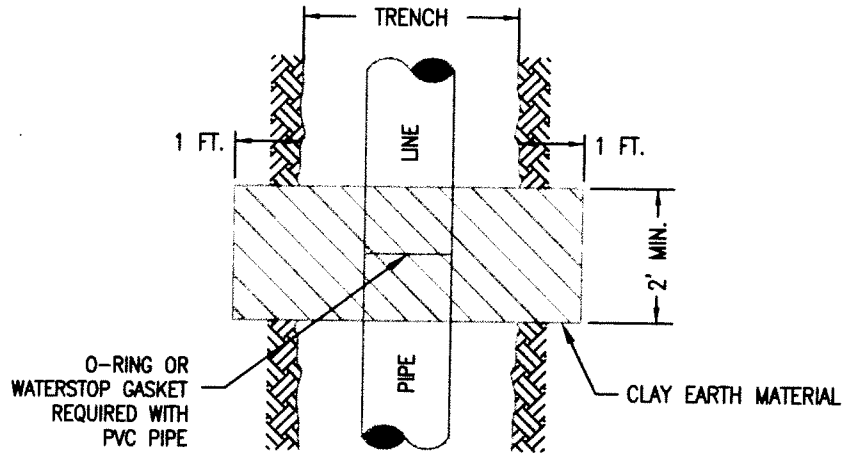

NOTES

1. CLAY WALL EXTENDS A MINIMUM OF 12" INTO UNDISTURBED SOIL ON EACH SIDE AND ON BOTTOM OF TRENCH.
2. CLAY MATERIAL TO BE CLASSIFIED AS CL, CH OR OH.
3. 3000 PSI CONCRETE MAY BE USED INSTEAD OF CLAY MATERIAL.



CUT-OFF WALL

APPROVED _____ FLG _____ DATE APRIL 2007 DWG CUT-OFF DETAIL S-2

C:\glick\CAD\win\Stds & Specs\Specs swr\AS3-swjt-enc.dwg, 5/19/2009 4:19:31 PM

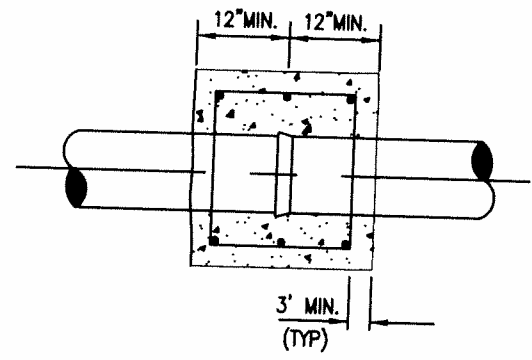
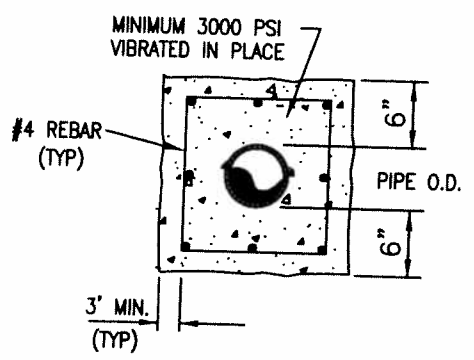
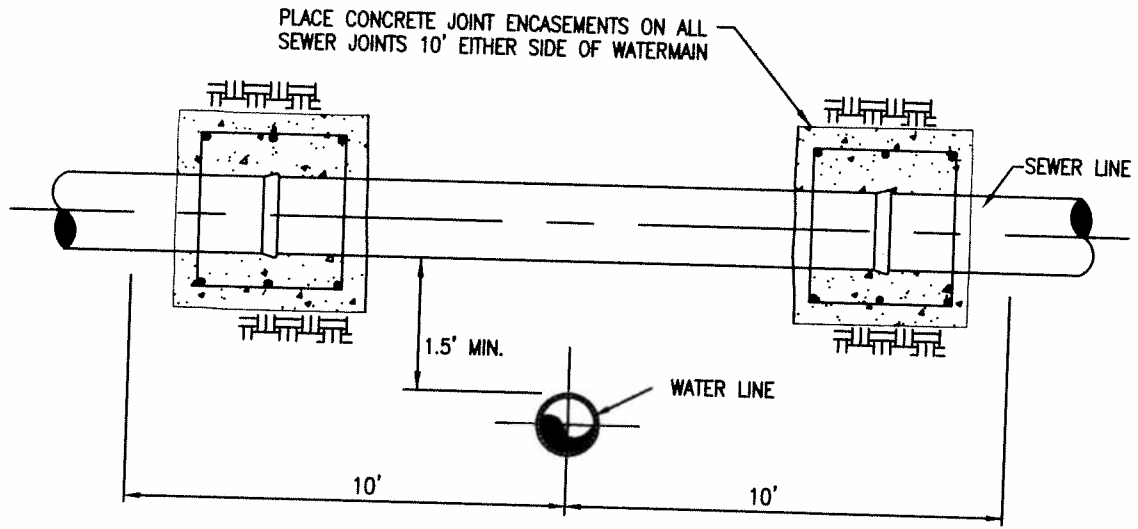

BAR SIZING AND LOCATION TABLE

PIPE I.D.	NO. OF LONGITUDINAL BARS AND LOCATION		
8-15 IN.	8 - NO. 4 BARS	3 EACH	SIDE
18 IN.	8 - NO. 4 BARS	3 EACH	SIDE



SEWER JOINT ENCASEMENT

APPROVED _____ FLG _____ DATE JANUARY 2008 DWG SWJT-ENC DETAIL S-3

C:\glick\CAD\win\stds & Specs\Specs swr\SA4-conc-enc.dwg, 5/19/2009 4:20:27 PM

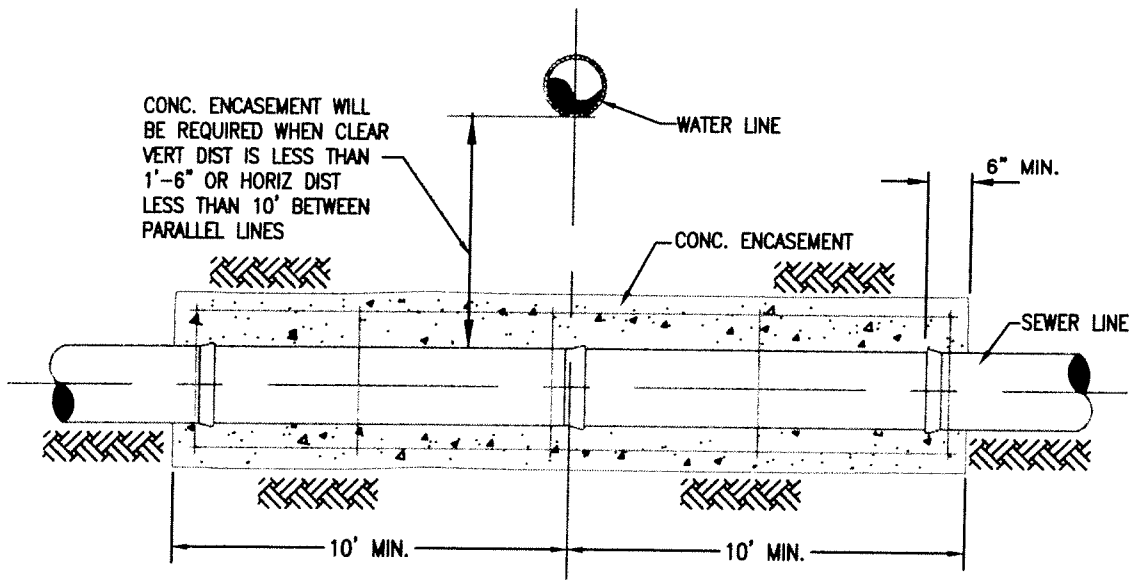
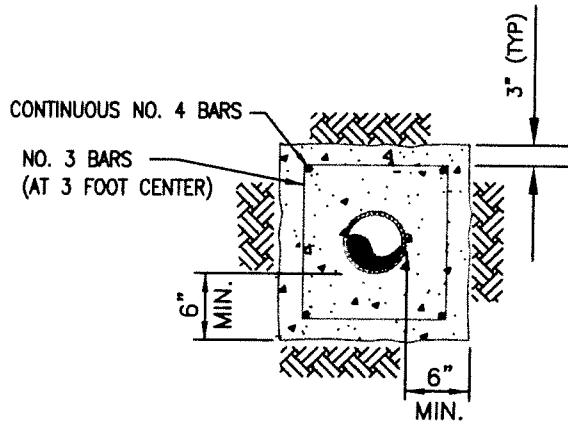

NOTE:

CONCRETE ENCASEMENT IS REQUIRED IN ALL CASES WHERE SEWER LINE IS ABOVE WATER LINE OR UNDER A WATER WAY.



CONCRETE ENCASEMENT DETAIL

APPROVED _____ FLG _____ DATE JANUARY 2008 DWG CONC-ENC DETAIL S-4

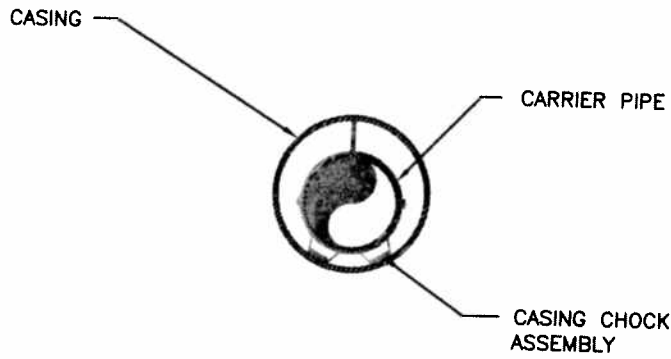

END SECTION

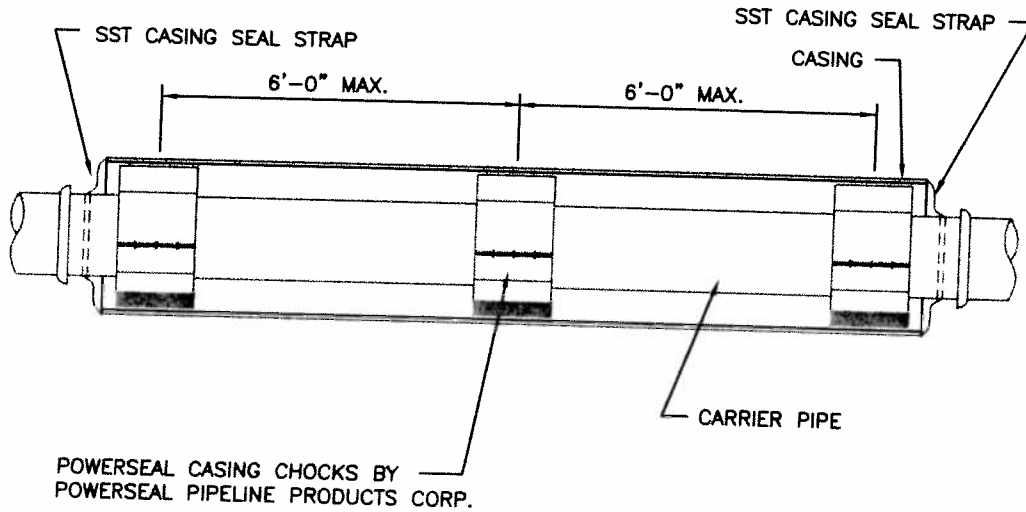

PIPE CASING DETAIL



APPROVED _____ FLG _____ DATE APRIL 1996 DWG PIPE-CAS DETAIL S-5

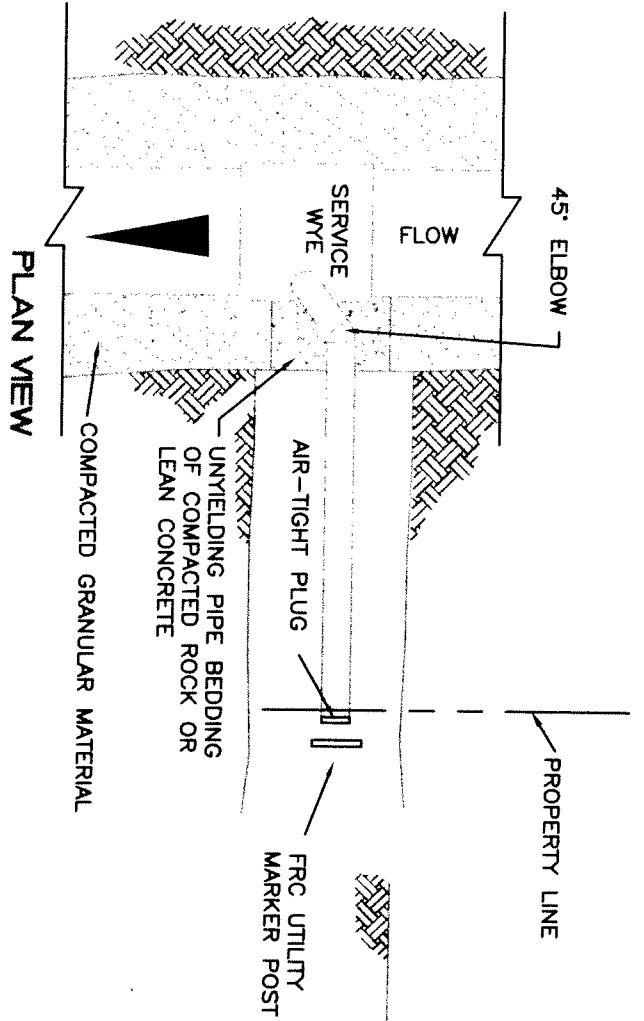
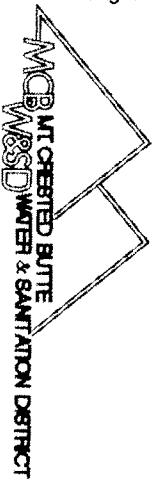

PLAN VIEW

UTILITY MARKER

COLOR:
APWA GREEN

LETTERING BY
MFG'R.

FIBERGLASS
REINFORCED
COMPOSITE

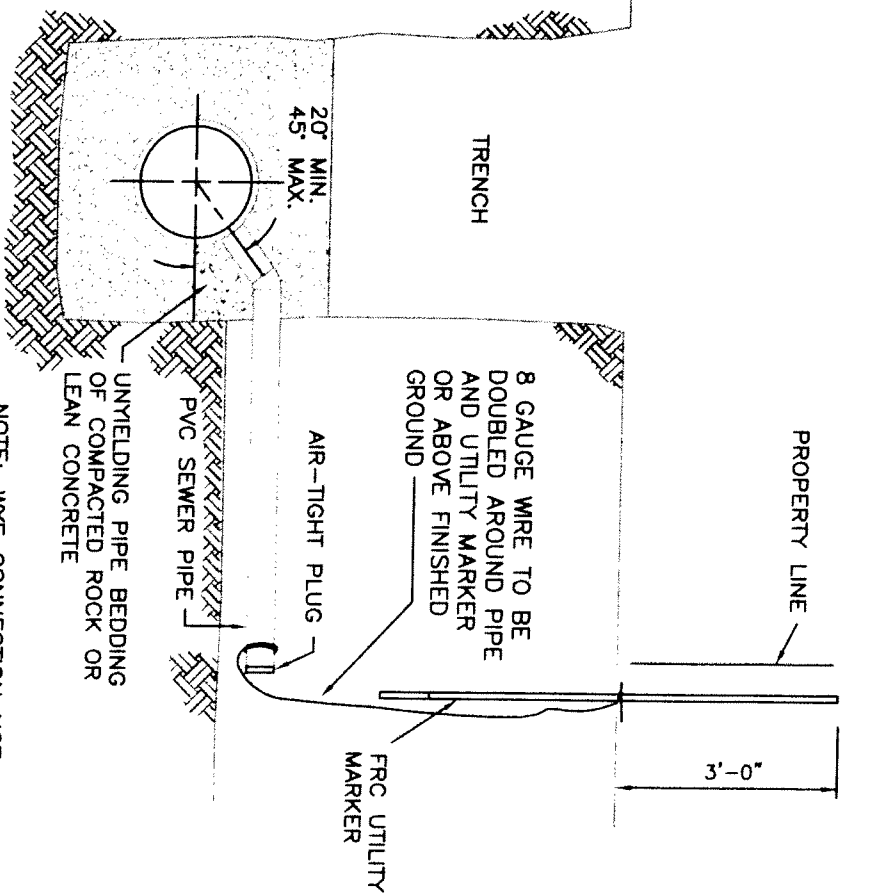

SECTION VIEW

NOTE: WYE CONNECTION NOT
ALLOWED ON VCP.

SEWER SERVICE PRETAP DETAIL

C:\glick\CAD\win\Strds & Specs\Specs sw\ST-sew-co.dwg, 5/21/2009 3:25:54 PM

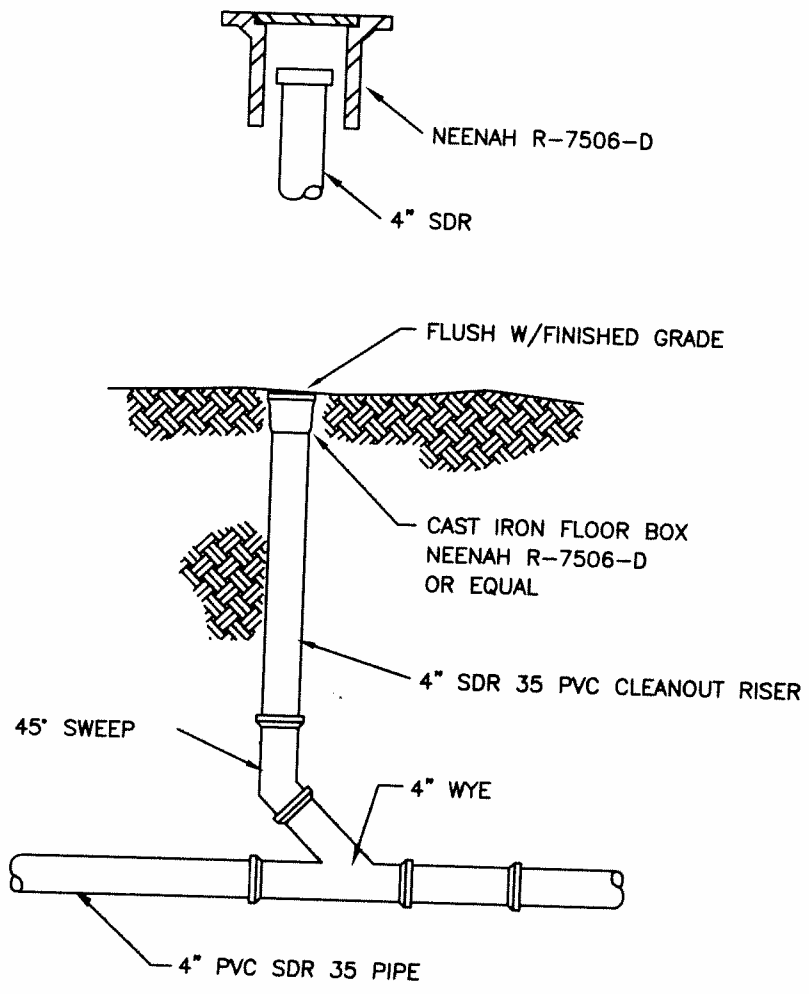

GEN NOTES

- 1. DISTRICT'S RESPONSIBILITY FOR MAINTENANCE SHALL BE THE SEWER MAIN. OWNER'S RESPONSIBILITY SHALL BE THE ENTIRE LENGTH OF THE SERVICE LINE, INCLUDING ANY CLEANOUTS, FROM THE MAIN TO THE BUILDING.
- 2. ACCESSIBLE CLEANOUTS WILL BE CONSTRUCTED EVERY 100 FT., OR AS OTHERWISE APPROVED BY THE DISTRICT.



SEWER SERVICE LINE CLEANOUT

APPROVED _____	FLG _____	DATE DEC 1999	DWG SEW-CO	DETAIL S-7
----------------	-----------	---------------	------------	------------

C:\glick\CAD\win\stds & Specs\Specs swr\SB-std-mh-pv.dwg, 5/21/2009 3:03:14 PM

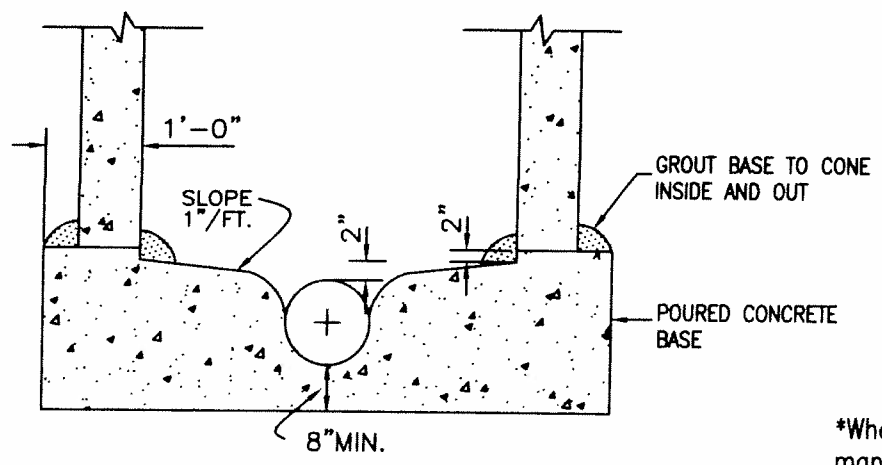
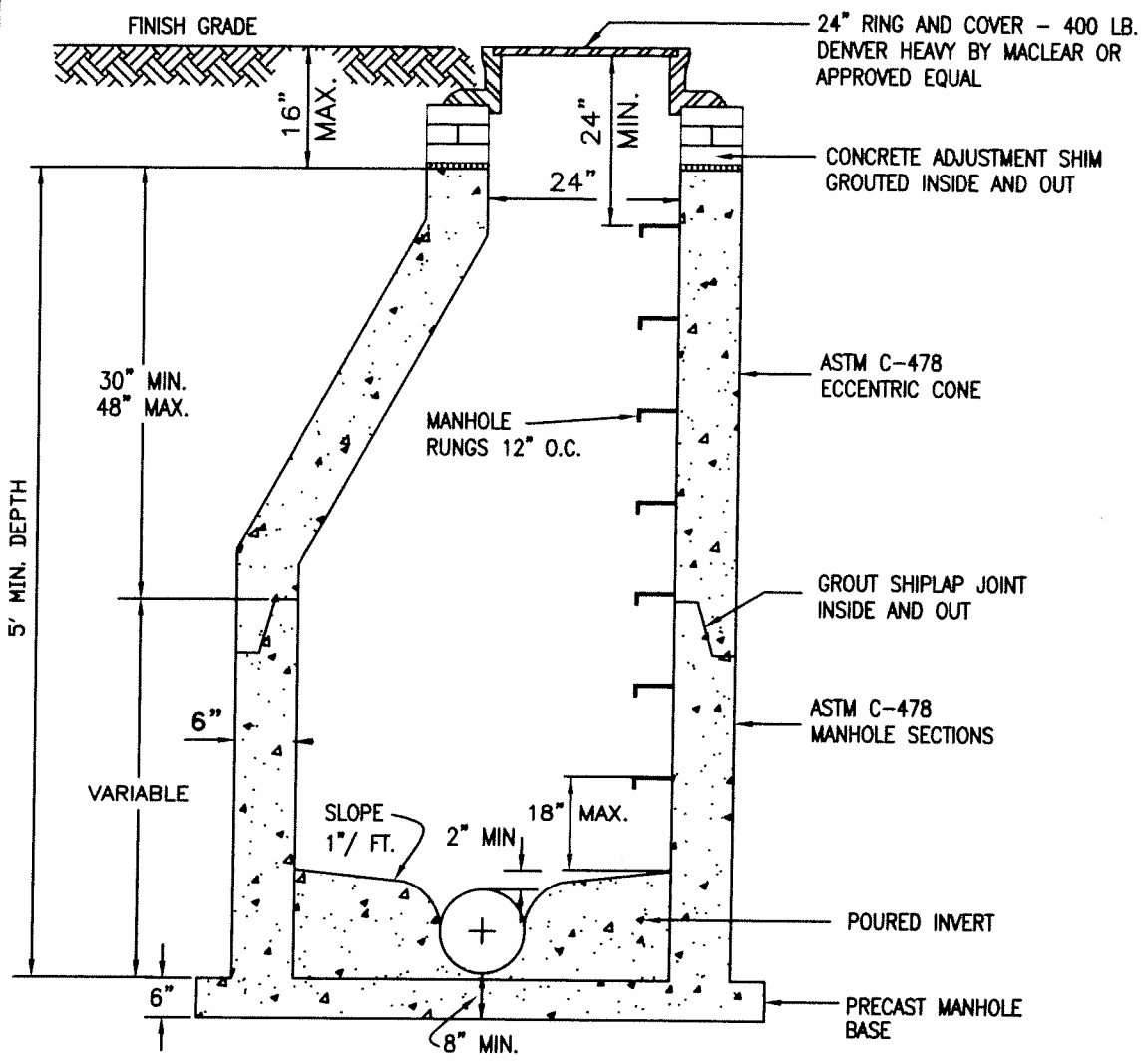

ALTERNATE BASE

NOTE:

MINIMUM INSIDE DIAMETER OF MANHOLE SHALL BE AS FOLLOWS:

PIPE SIZE	MIN. MANHOLE DIAMETER
15" OR LESS *	48"
18" - 48" *	60"
54" OR LARGER	72"

*Whenever more than a two-way manhole of maximum pipe I.D. is required, the manhole must be increased to next largest diameter.



STANDARD MANHOLE IN PAVED AREAS

APPROVED _____ FLG _____ DATE JANUARY 2008 DWG STD-MH-PV DETAIL S-8

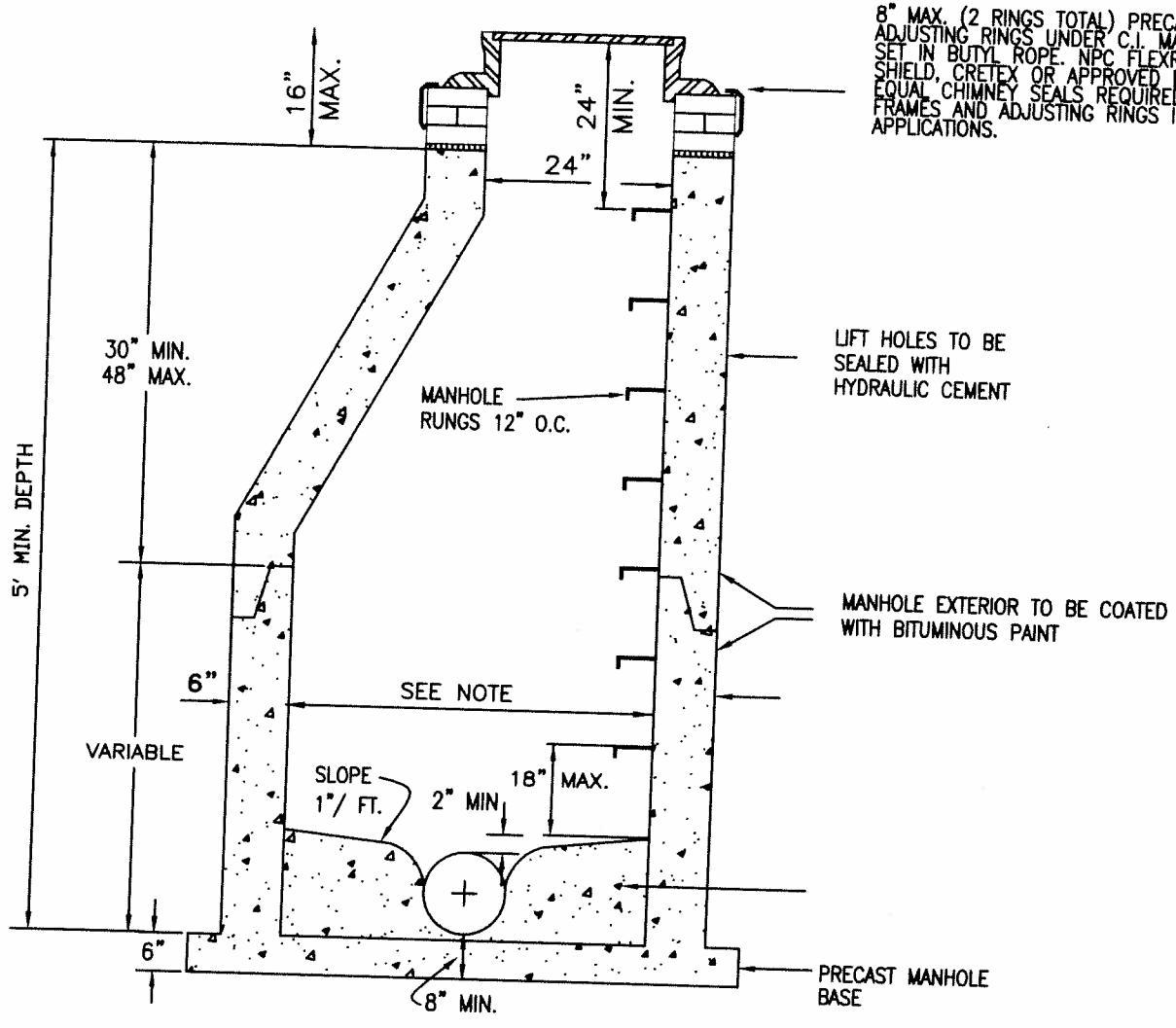

8" MAX. (2 RINGS TOTAL) PRECAST CONCRETE ADJUSTING RINGS UNDER C.I. MANHOLE FRAME SET IN BUTYL ROPE. NPC FLEXRIB, INFI-SHIELD, CRETEX OR APPROVED EQUAL EQUAL CHIMNEY SEALS REQUIRED FOR ALL FRAMES AND ADJUSTING RINGS IN ALL APPLICATIONS.

NOTE:

MINIMUM INSIDE DIAMETER OF MANHOLE SHALL BE AS FOLLOWS:

PIPE SIZE	MIN. MANHOLE DIAMETER
15" OR LESS *	48"
18" - 48" *	60"
54" OR LARGER	72"

*Whenever more than a two-way manhole of maximum pipe I.D. is required, the manhole must be increased to next largest diameter.

C:\glick\CAD\win\stds & Specs\Specs swr\S9-std-mh-unpv.dwg, 5/21/2009 3:03:58 PM



STANDARD MANHOLE IN UNPAVED AREAS

APPROVED _____ FLG _____	DATE <u>JANUARY 2008</u>	DWG <u>STD-MH-UNPV</u>	DETAIL <u>S-9</u>
--------------------------	--------------------------	------------------------	-------------------

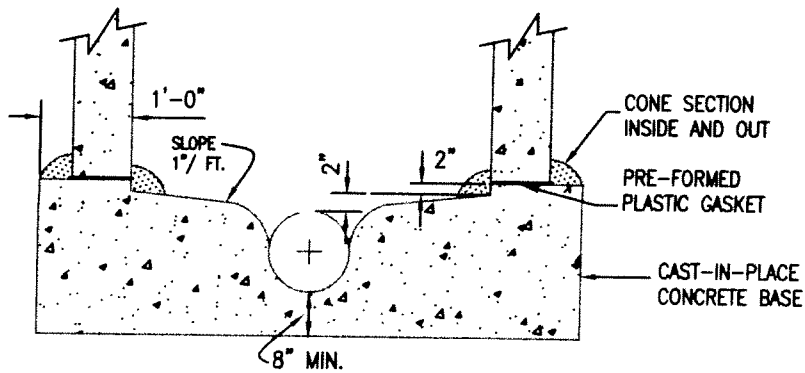
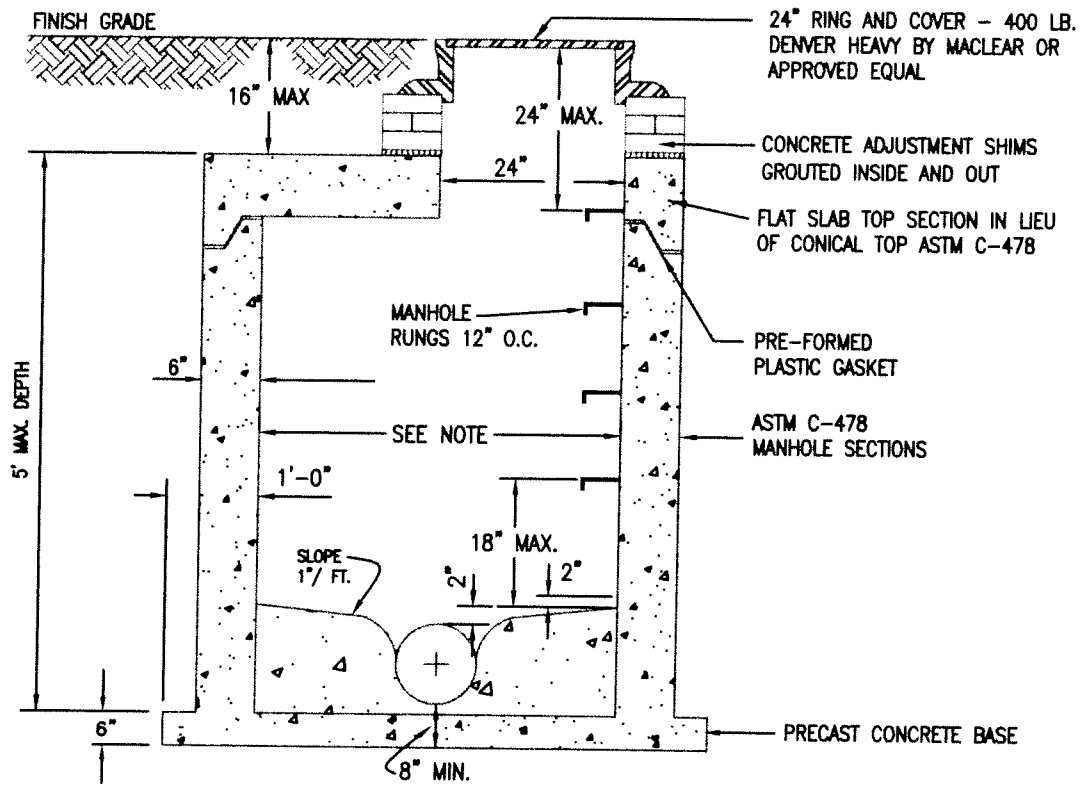

ALTERNATE BASE

NOTE: IF MANHOLE DEPTH IS LESS THAN 3 FEET
TOP SECTION SHALL BE CONCENTRIC.

FLAT-TOP MANHOLE



C:\glick\CAD\win\stds & Specs\Specs swr\S11-drop-mh.dwg, 5/21/2009 3:16:56 PM

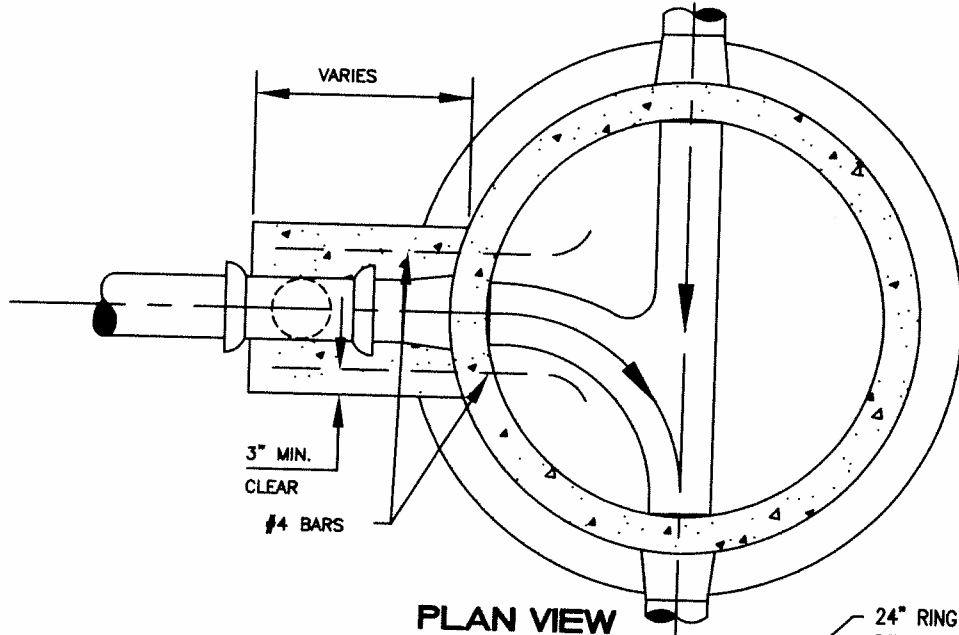

PLAN VIEW

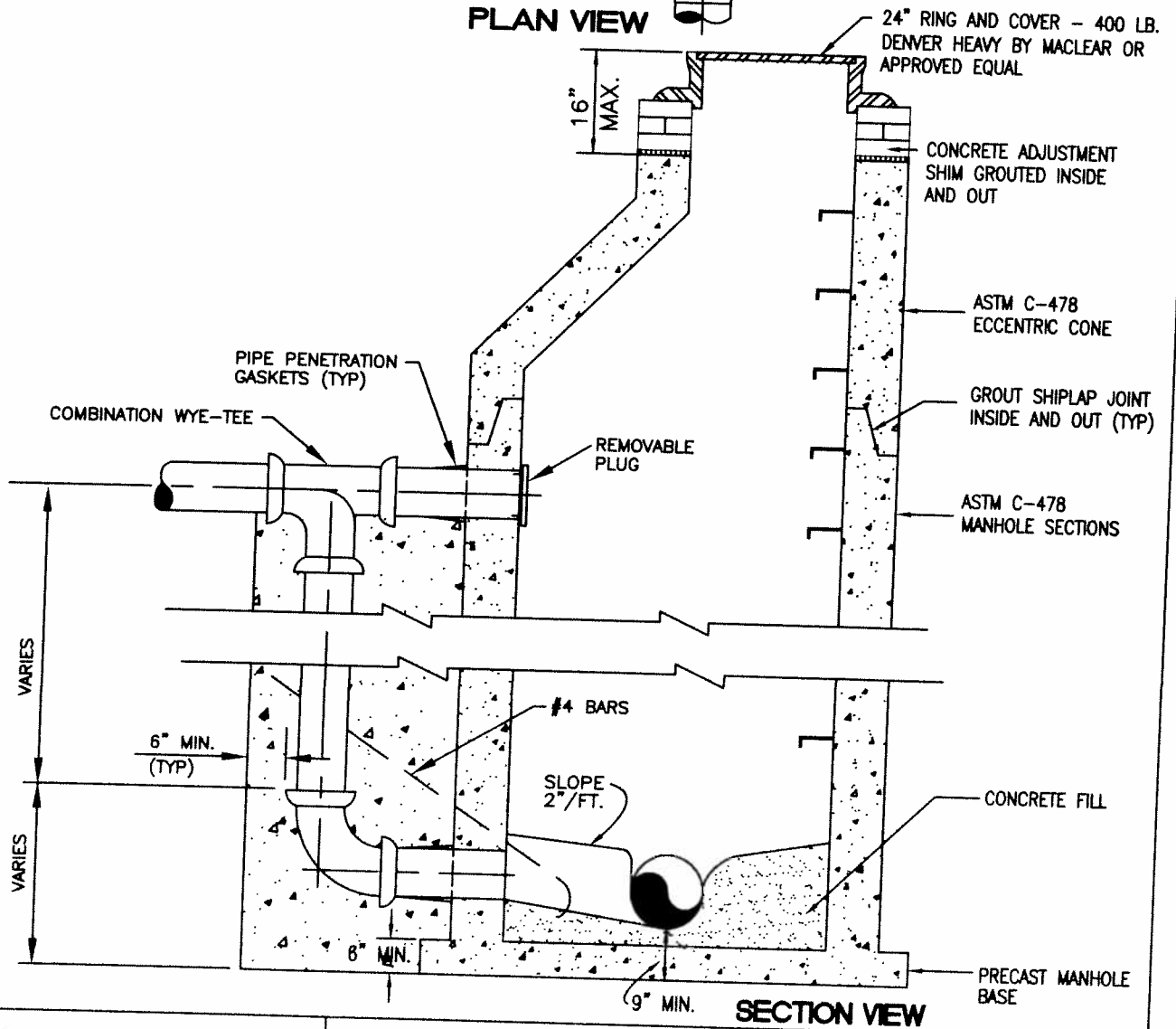

SECTION VIEW

PRECAST DROP MANHOLE



APPROVED _____	FLG _____	DATE APRIL 1996	DWG DROP-MH	DETAIL S-11
----------------	-----------	-----------------	-------------	-------------

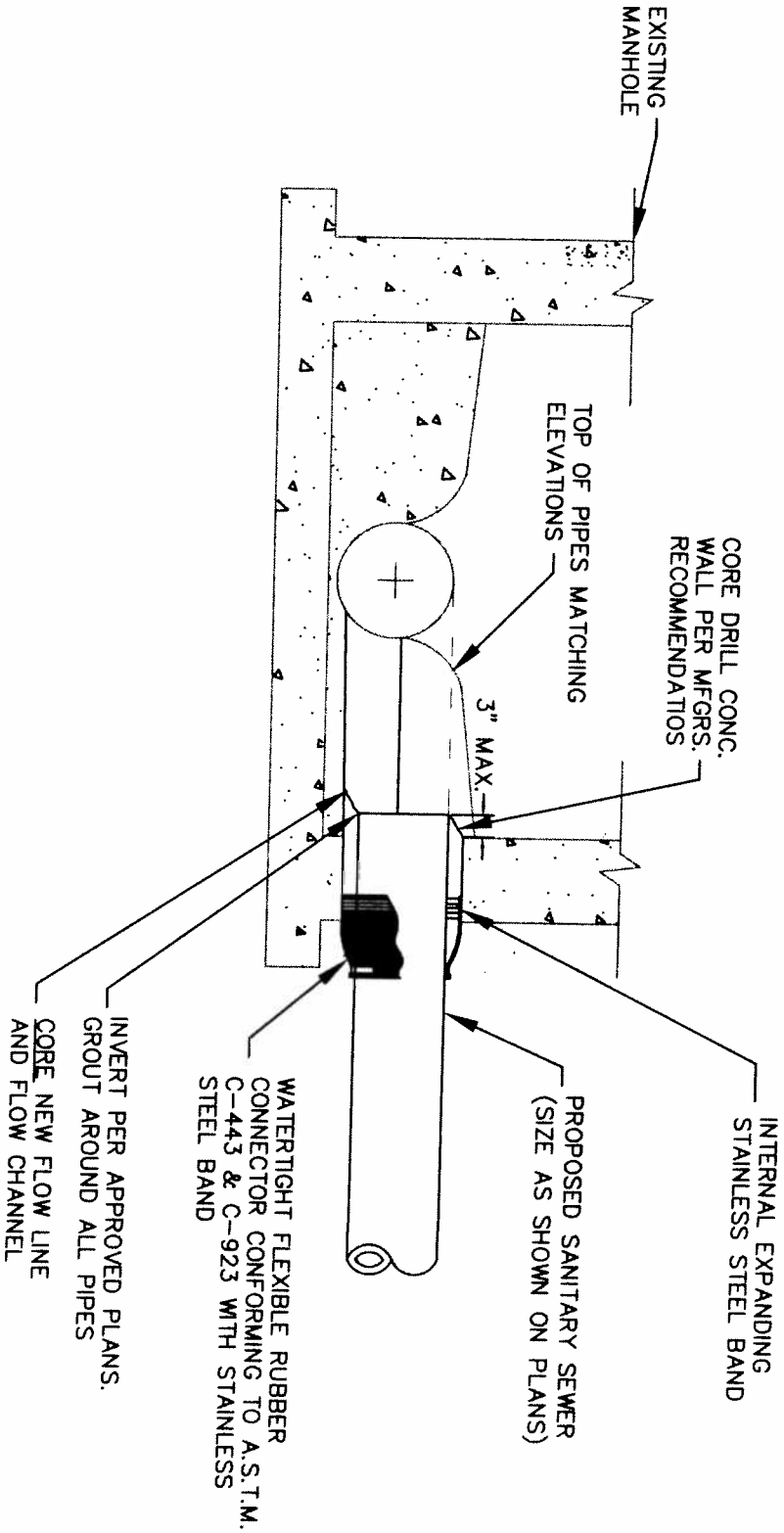
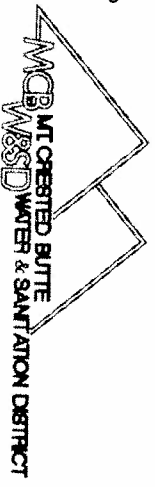

PIPE TO MANHOLE CONNECTION

APPROVED _____ FLAG _____ DATE AUGUST 2007 DWG PIPE-MH DETAIL S-12

C:\glick\CAD\win\stds & Specs\Specs sw\13-mh-step.dwg, 5/21/2009 4:26:43 PM

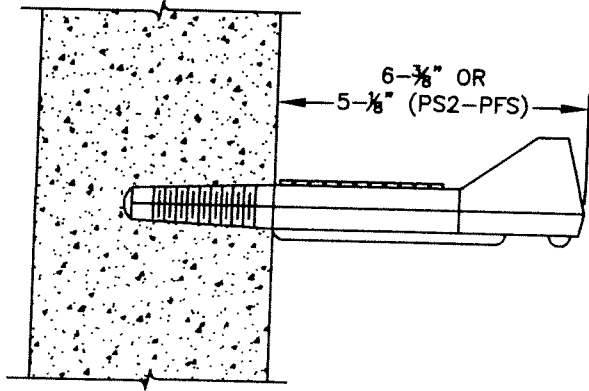
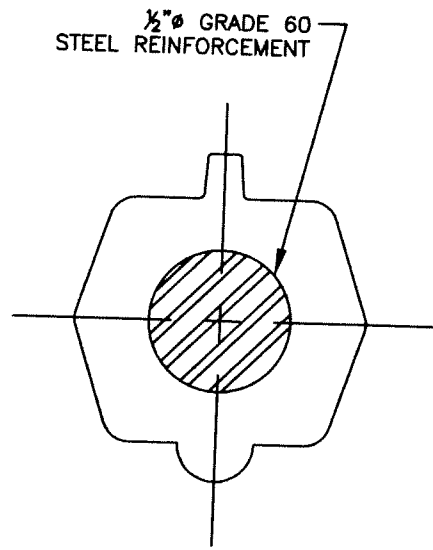
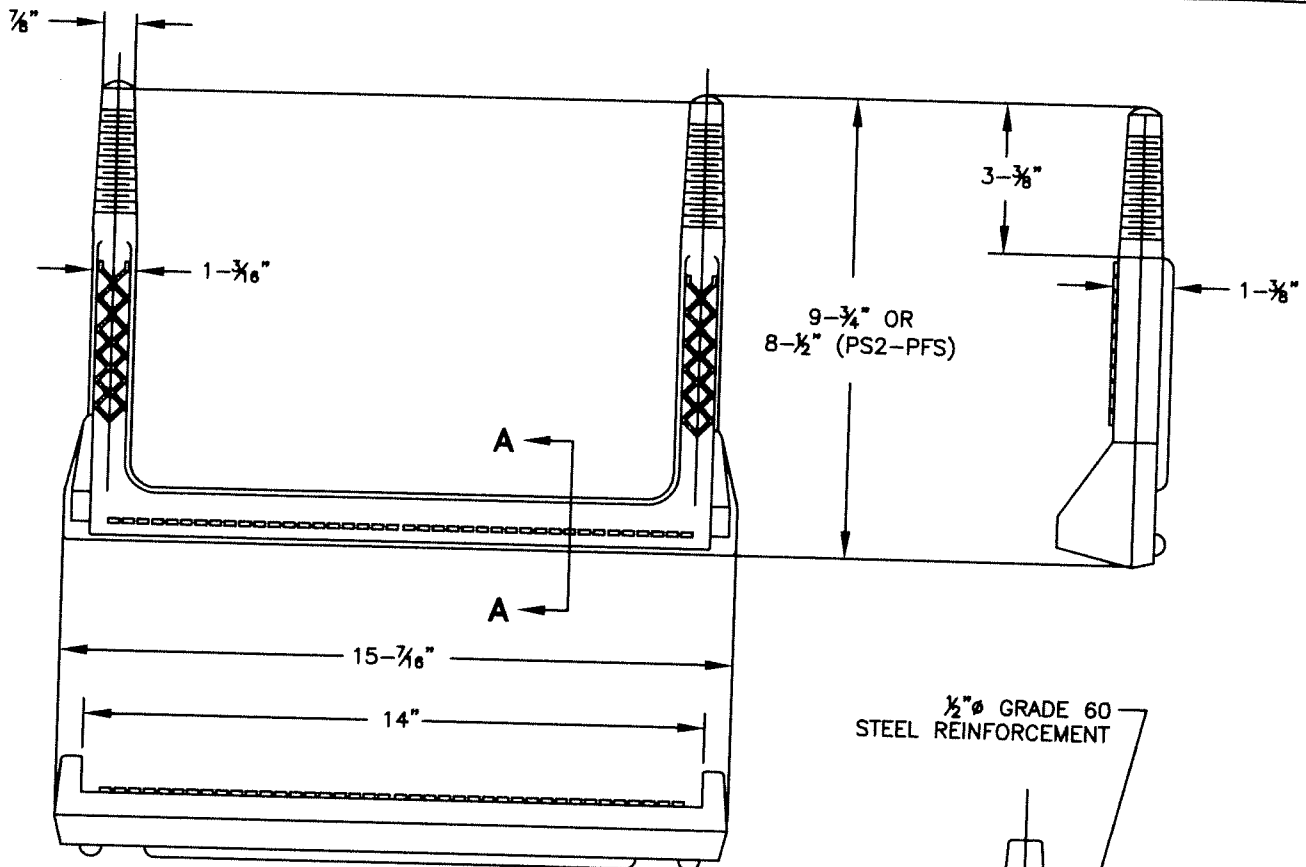

NOTES:

- 1). AS MANUFACTURED BY M.A. INDUSTRIES PART NO. PS2-PF OR PS2-PFS.
- 2). CAPACITY 2,500 LBS. WITH STEP EXTENDED $6\text{--}\frac{3}{8}$ " FROM WALL.
- 3). MATERIAL COPOLYMER POLYPROPYLENE PLASTIC, WITH $1/2$ " ϕ GRADE 60 STEEL REINFORCEMENT.



MANHOLE STEP

APPROVED _____	FLG _____	DATE JANUARY 2008	DWG MH-STEP	DETAIL S-13
----------------	-----------	-------------------	-------------	-------------

C:\glick\CAD\win\Std & Spec\Specs sw\MS14-mh-rt-wall.dwg, 5/21/2009 4:28:55 PM

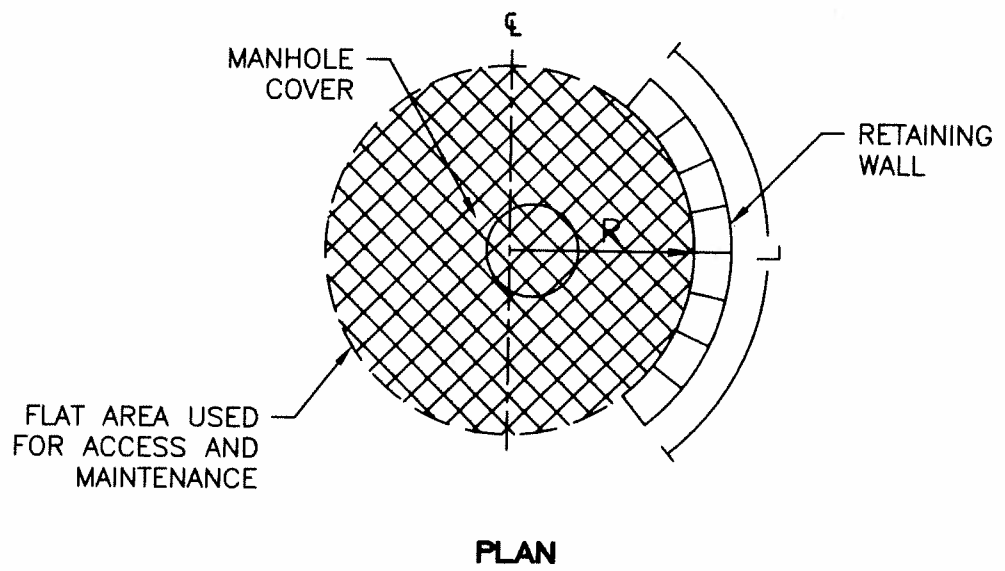

PLAN

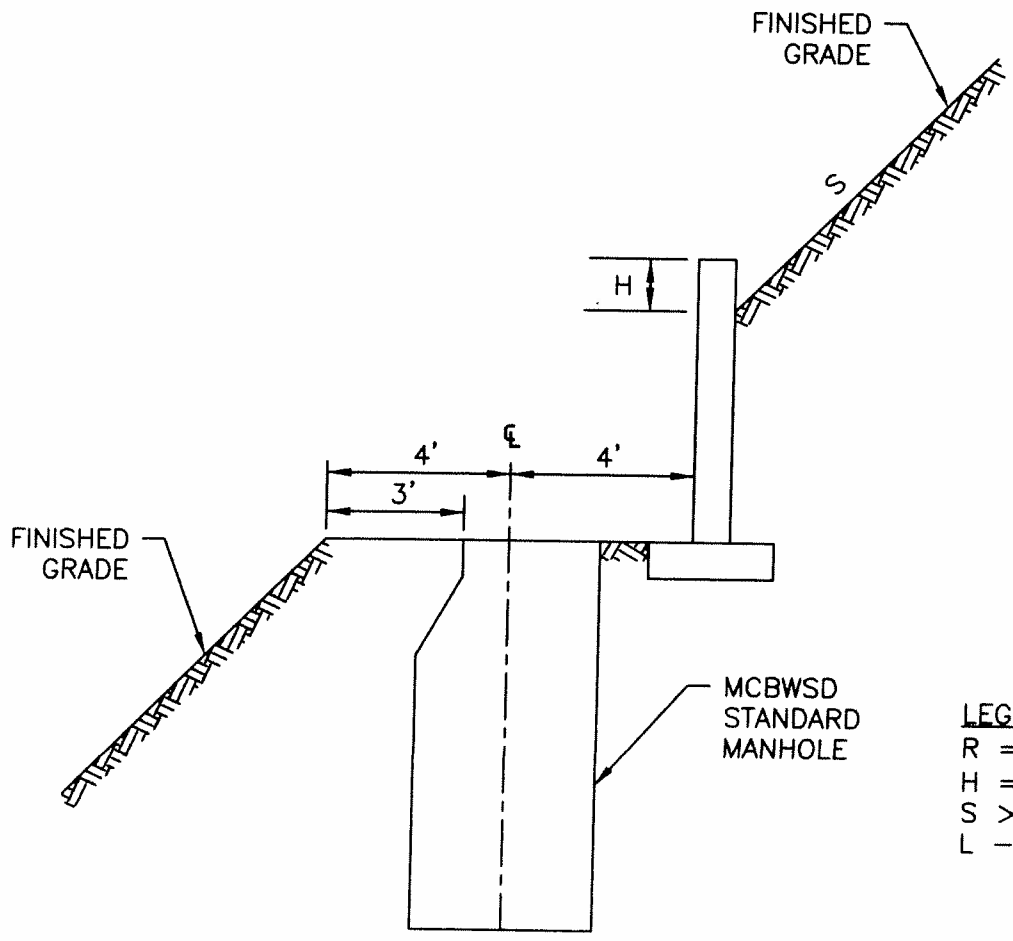

SECTION

- LEGEND**
- R = 4' MIN.
 - H = 6" MIN.
 - S > 2H:1V
 - L - TBD BY SITE CONDITIONS

NOTE:
RETAINING WALL DESIGN
TO BE SUBMITTED ON
ENGINEERED AND STAMPED
PLANS BY COLORADO P.E. TO
THE MCBWS D FOR REVIEW.



MANHOLE RETAINING WALL

APPROVED <u>FLG</u>	DATE <u>AUGUST 2007</u>	DWG <u>MH-RT-WALL</u>	DETAIL <u>S-14</u>
---------------------	-------------------------	-----------------------	--------------------

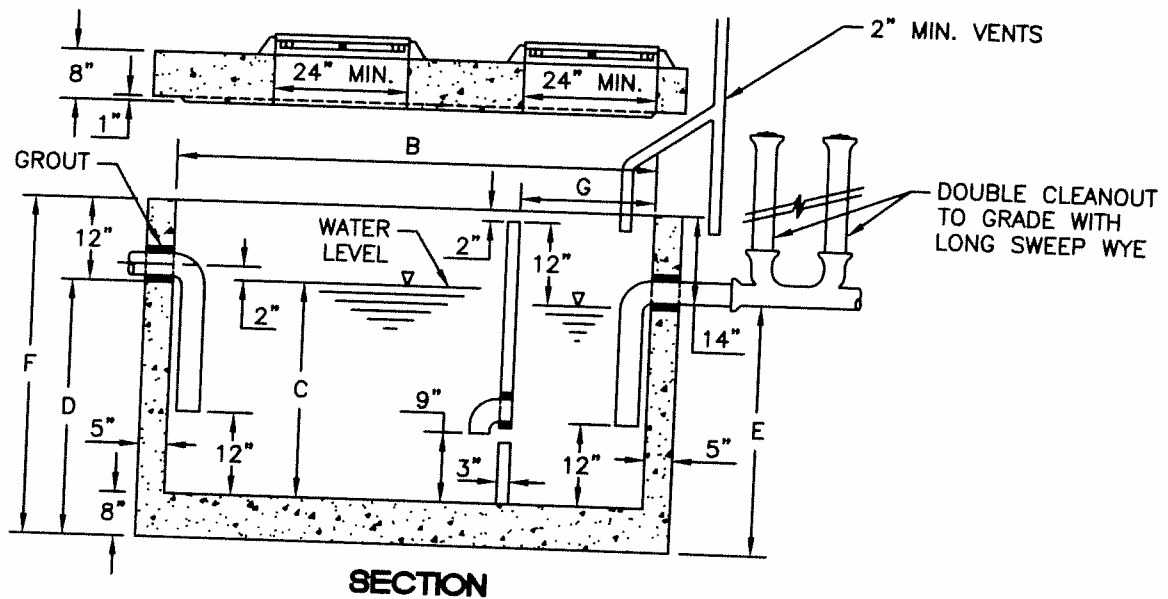
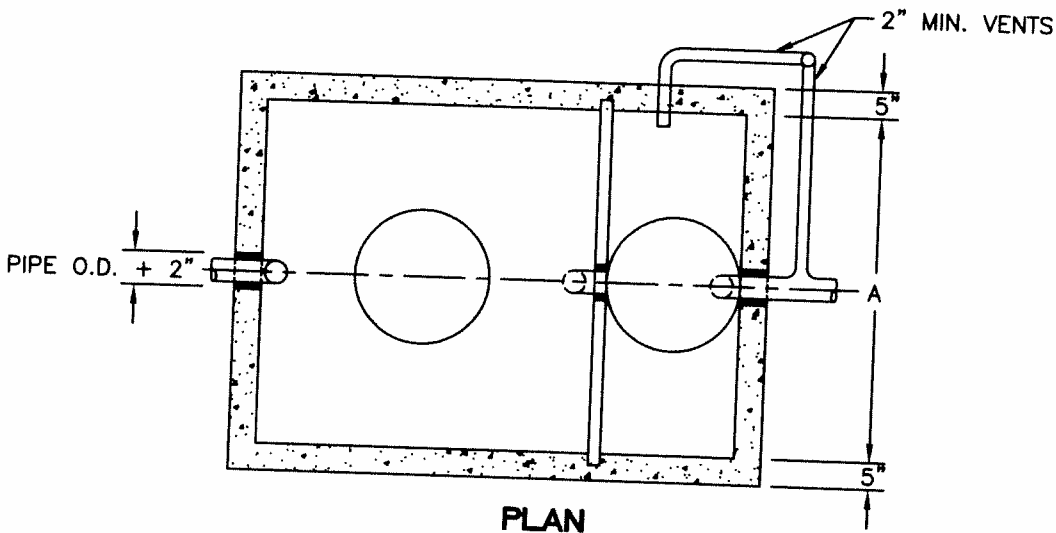

WATER CAPACITY APPROX. GALLONS	GREASE CAPACITY APPROX. CUBIC FT.	DIMENSIONS FOR TWO COMPARTMENT TANK IN INCHES						
		A	B	C	D	E	F	G
650 MIN. SIZE								
780	47	48	96	40	50	48	62	20
1060	74	72	102	34	44	42	56	30
1250	87	80	112	35	43	41	57	36

APPROXIMATE SIZES OF GREASE INTERCEPTOR. CHECK WITH MANUFACTURERS FOR CORRECT SIZES AND BIGGER INTERCEPTORS.

NOTES:

1. BAFFLE WALL INSERTS TO BE SEALED IN PLACE.
2. OUTLET PIPE INVERT TO BE 2" LOWER THAN INLET.
3. SUPPORT BRACKETS AND CLEAN OUT CAPS SHALL BE BRASS.
4. WALLS AND BOTTOM TO BE REINFORCED WITH 2 X 16 6/10 REMESH.
5. MANHOLE COVERS AND CLEAN OUT CAPS SHALL NOT FALL BELOW GRADE.
6. MANHOLE RING AND COVER SHALL BE NEENAH R-1706 OR APPROVED EQUAL.
7. ALL JOINTS IN PRECAST JOINT SECTIONS TO BE SEALED WITH FLEXIBLE JOINT SEALING COMPOUND.
8. ALL PIPING TO BE CAST IRON OR SCHEDULE 40 PVC WITH A MINIMUM DIAMETER OF 4" UNLESS OTHERWISE NOTED.
9. VENT PIPES TO BE CAST IRON OR SCHEDULE 40 PVC.
10. INLET AND OUTLET RISER PIPES LONGER THAN 12" SHALL BE ANCHORED TO WALL AT 4" ABOVE PIPE OPENING.

C:\glick\CAD\win\stds & Specs\Specs swr\S15-sew-intrsptr.dwg, 5/21/2009 4:46:49 PM



TYPICAL EXTERIOR GREASE INTERCEPTOR

APPROVED _____ FLG _____ DATE APRIL 2007 DWG SEW-INTRSPTR DETAIL S-15

INTERNAL GREASE TRAP RESTAURANT SCHEMATIC

SINGLE INSTALLATION FULLY RECESSED IN FLOOR

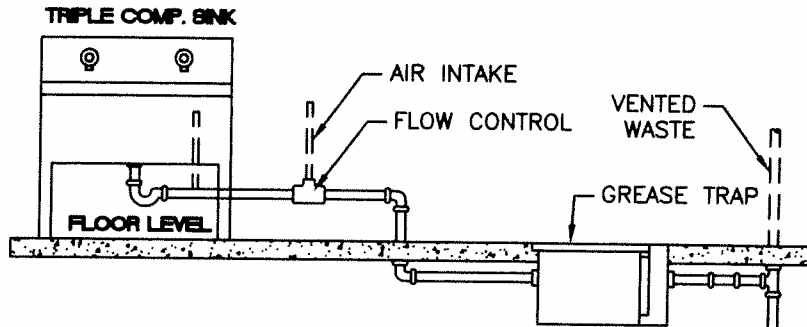

RECESSED WITH EXTENSION TO FLOOR LEVEL

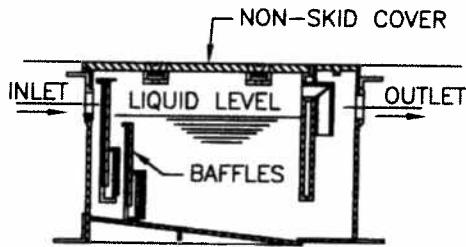
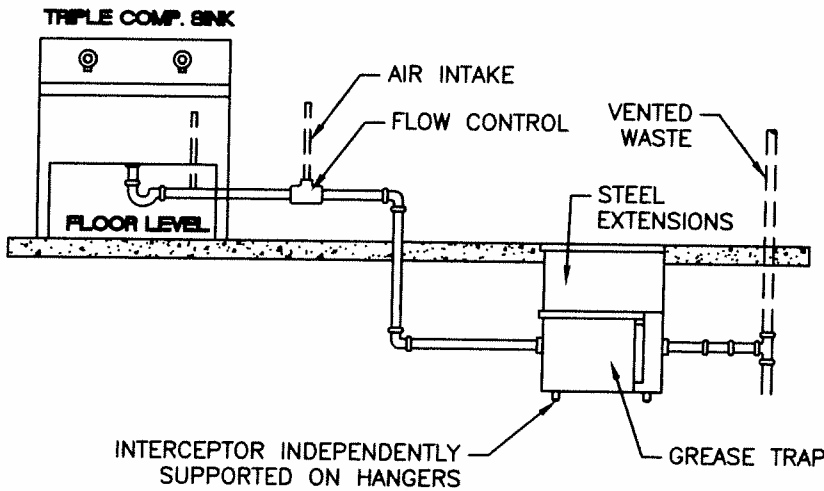

TYPICAL MODEL
VARIES WITH MAKE AND MODEL

GREASE TRAPS

GREASE CAPACITY LBS.	FLOW RATE GPM.	LENGTH	WIDTH	HEIGHT
100	50	33-3/8"	22"	23-1/2"
150	50	40-5/8"	22"	23-1/2"

APPROXIMATE SIZE OF GREASE TRAPS.
CHECK WITH MANUFACTURERS FOR CORRECT DIMENSIONS AND INVERTS.

C:\glick\CAD\win\Stds & Specs\Specs sw\16-sew-trap.dwg, 5/21/2009 4:47:48 PM



TYPICAL INTERIOR GREASE TRAP

APPROVED _____ FLG _____

DATE APRIL 2007

DWG SEW-TRAP

DETAIL S-16